

## Typical Gravity Wall Section

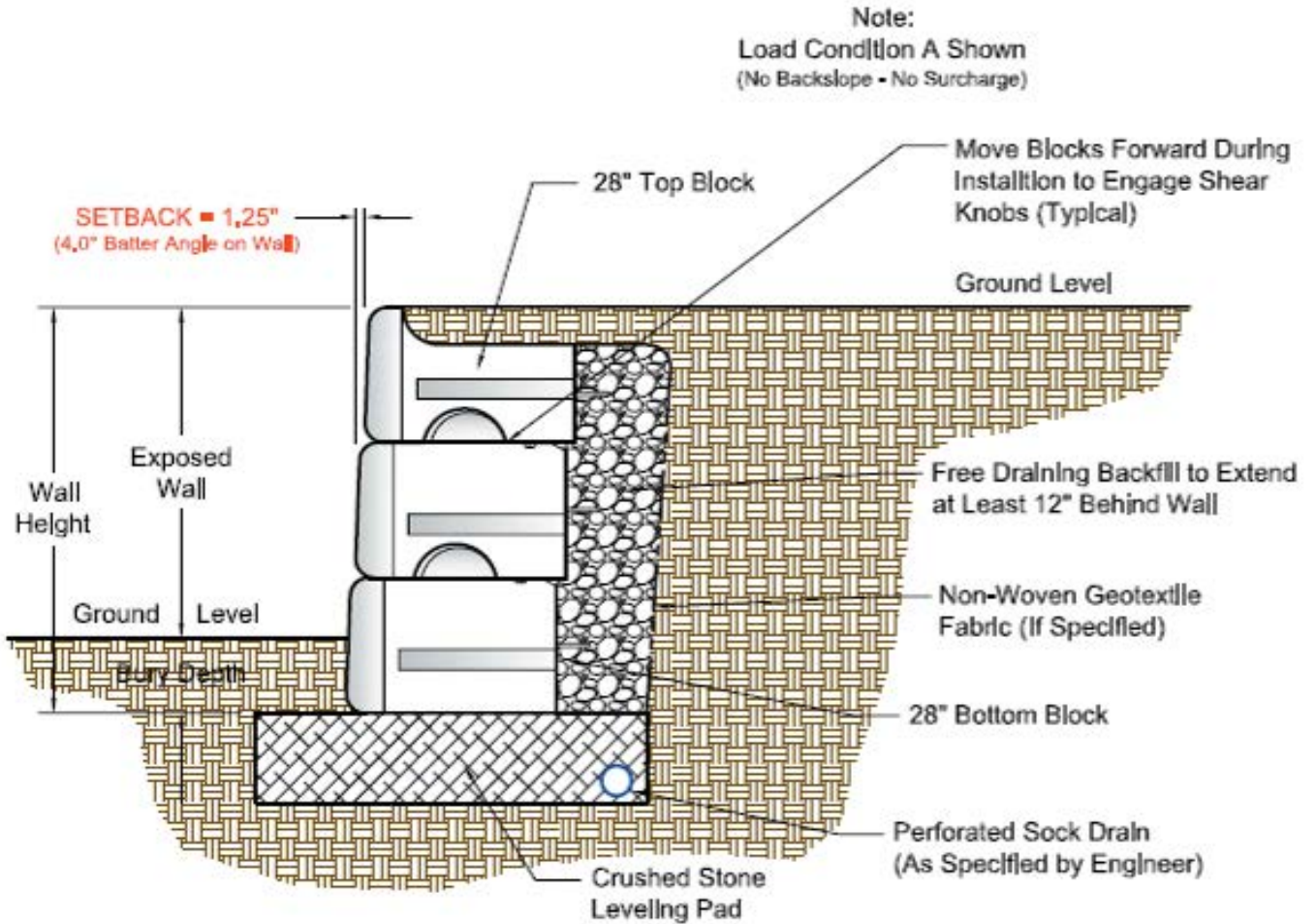

This drawing is for reference only. Determination of the suitability and/or manner of use of any details contained in this document is the sole responsibility of the design engineer of record. Final project designs, including all construction details, shall be prepared by a licensed professional engineer using the actual conditions of the proposed site.

DRAWN BY:  
APPROVED BY:  
DATE:  
SHEET: 1 of 1

TITLE:  
**Typical 28" Block Gravity Wall**  
FILE:



## Typical Gravity Wall Section

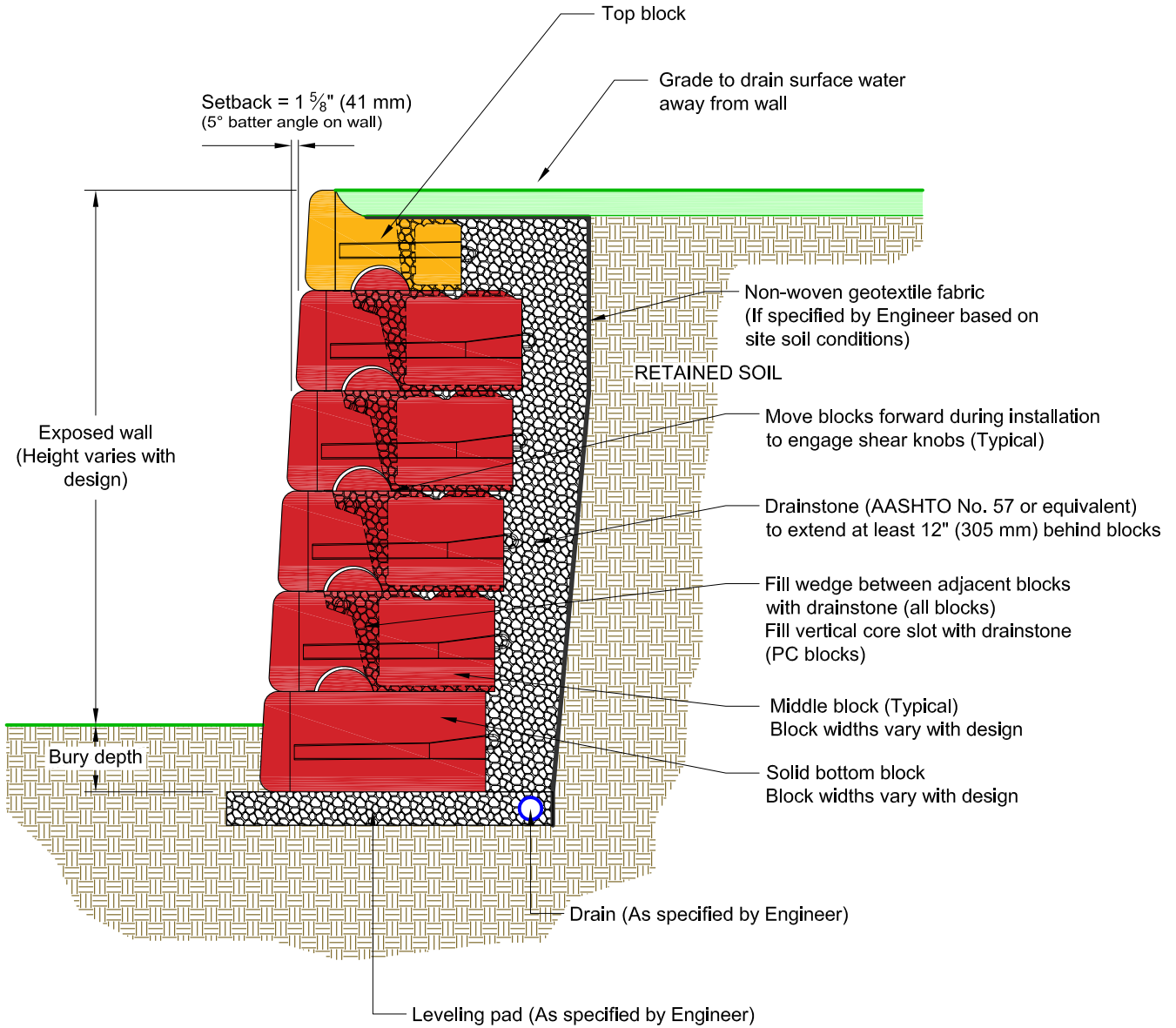

This drawing is for reference only. Determination of the suitability and/or manner of use of any details contained in this document is the sole responsibility of the design engineer of record. Final project designs, including all construction details, shall be prepared by a licensed professional engineer using the actual conditions of the proposed site.

DRAWN BY:	JRJ
APPROVED BY:	JRJ
DATE:	17MAR2016
SHEET:	1 of 1

TITLE:	<h3>Typical Gravity Wall Detail</h3>
FILE:	



## Sample Plan and Profile Gravity Wall

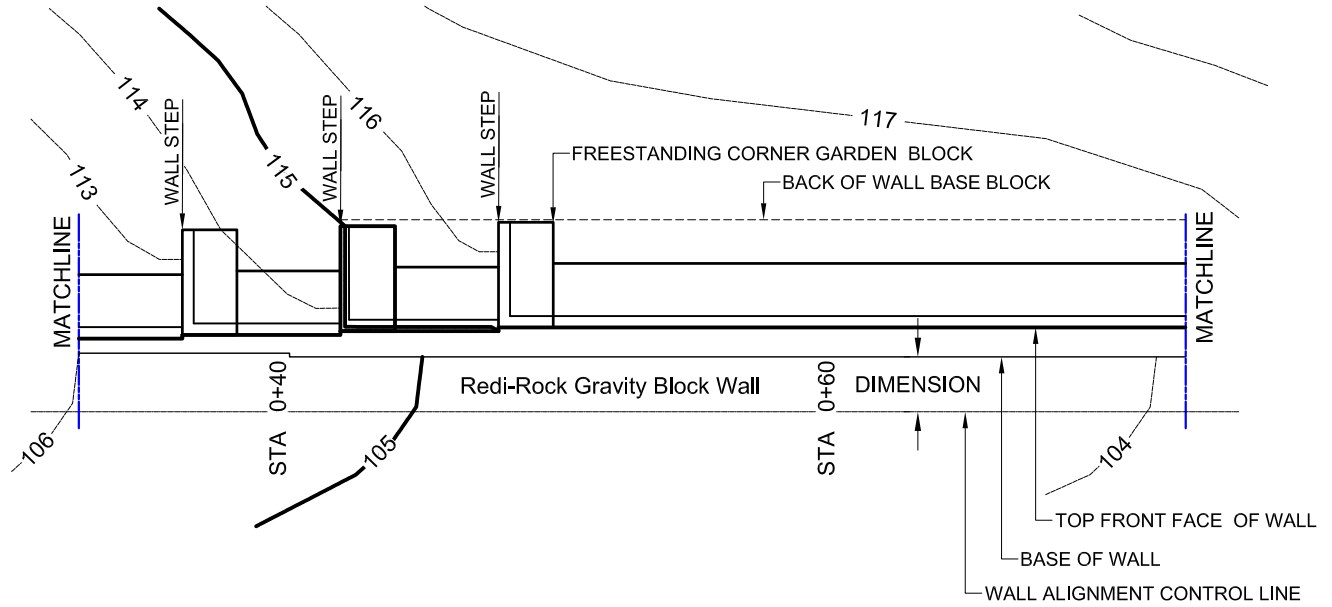

**LEGEND:**

- BLOCK SERIES (RETAINING, FREESTANDING, ACCESSORY)
- BLOCK SIZE (28, 41, & 60)
- R-41M — BLOCK TYPE (BOTTOM, MIDDLE, TOP or CORNER GARDEN)

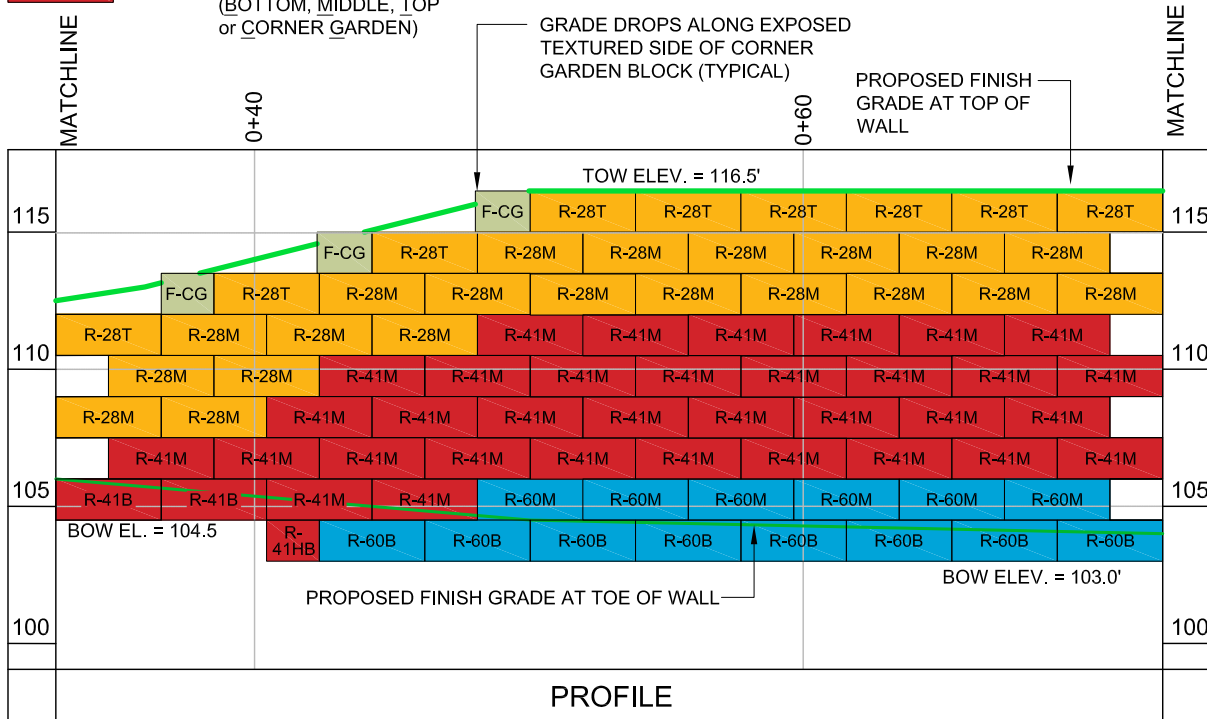

- This drawing is for reference only.
- Final designs for construction must be prepared by a registered Professional Engineer using the actual conditions of the proposed site.
- Final wall design must address both internal and external drainage and shall be evaluated by the Professional Engineer who is responsible for the wall design.

DRAWN BY:	JRJ
APPROVED BY:	JRJ
DATE:	22MAR2016
SHEET:	1 of 1

TITLE:	<b>Sample Plan and Profile Gravity Wall</b>
FILE:	2 Sample Plan and Profile Gravity Wall 032216.dwg



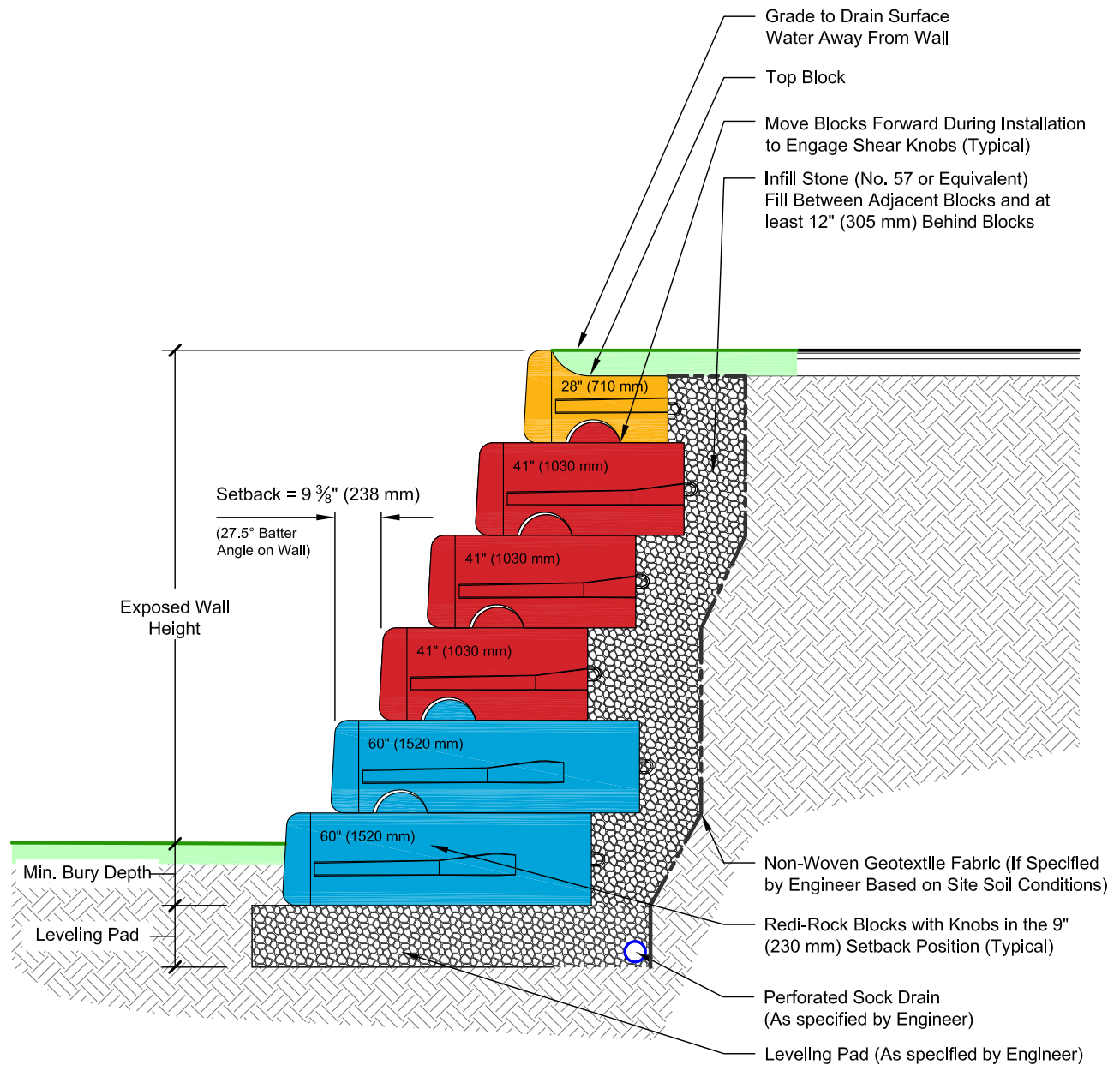

This drawing is for reference only. Determination of the suitability and/or manner of use of any details contained in this document is the sole responsibility of the design engineer of record. Final project designs, including all construction details, shall be prepared by a licensed professional engineer using the actual conditions of the proposed site. Final wall design must address both internal and external drainage and all modes of wall stability.

DRAWN BY: B. Lindfors	TITLE: <b>Large Batter Wall Section</b>	<b>REDI-ROCK®</b>
APPROVED BY: J. Johnson		
DATE: Jan 28, 2016		
SHEET: 1 of 1	FILE: Large Batter Gravity Wall Section 012816.dwg	

# BLOCK-TO-BLOCK SETBACK OPTIONS

NO SCALE

## Five degree (5°) setback (Standard)

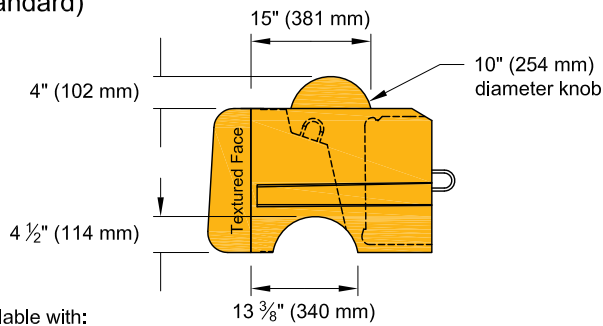

Setback =  $1 \frac{5}{8}$ " (41 mm)  
(5° batter angle on wall)

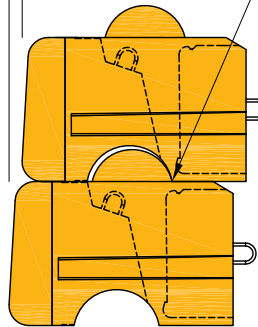

Available with:

- 28" (710 mm) blocks, 41" (1030 mm) blocks, and 60" (1520 mm) blocks
- 28" (710 mm) PC blocks (shown here) and 41" (1030 mm) PC blocks

## One degree (1°) setback (Specialty)

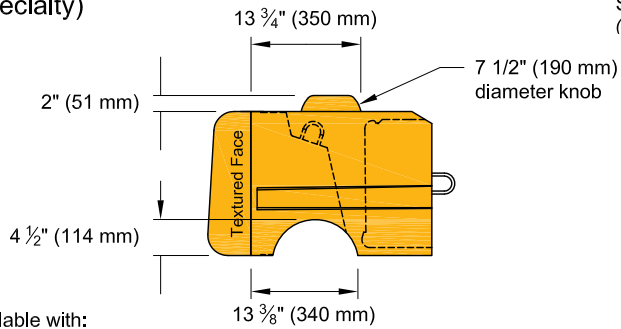

Setback =  $\frac{3}{8}$ " (10 mm)  
(1° batter angle on wall)

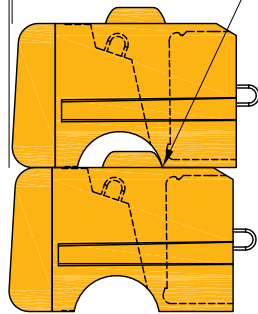

Available with:

- 28" (710 mm) blocks, 41" (1030 mm) blocks, and 60" (1520 mm) blocks
- 28" (710 mm) PC blocks (shown here) and 41" (1030 mm) PC blocks

## Zero (0°) setback (Specialty)

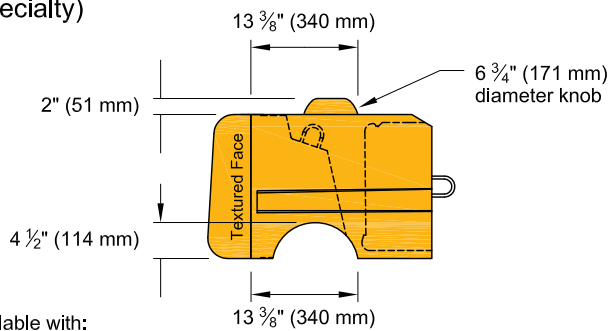

Setback = 0" (0 mm)  
(0° batter angle on wall)

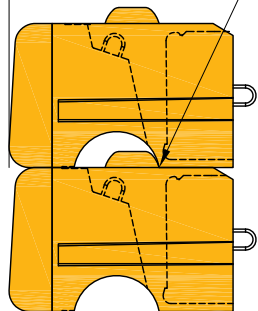

Available with:

- 28" (710 mm) blocks, 41" (1030 mm) blocks, and 60" (1520 mm) blocks
- 28" (710 mm) PC blocks (shown here) and 41" (1030 mm) PC blocks

The block-to-block setback available with Redi-Rock is controlled by the size and location of the shear knobs (domes) cast into the blocks. While the 10" (254 mm) diameter knob and the 1 5/8" (41 mm) setback position is the most common configuration, Redi-Rock has three different knob sizes and three different locations available.

DRAWN BY:	JRJ
APPROVED BY:	JRJ
DATE:	06-22-2015
SHEET:	1 of 1

TITLE:	<h3>Block Setback Options Normal Batter</h3>
FILE:	



# BLOCK-TO-BLOCK SETBACK OPTIONS

NO SCALE

## 9" (230 mm) Setback Blocks

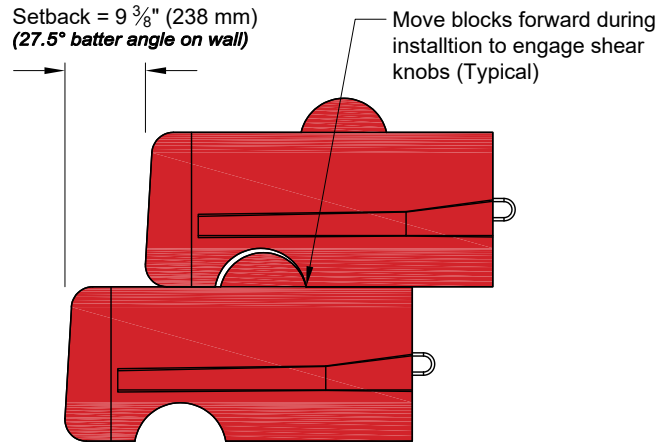
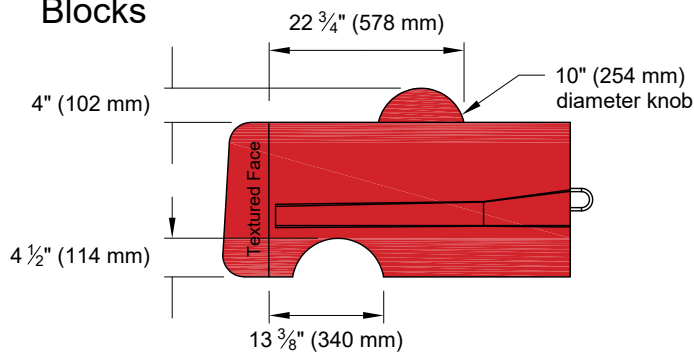

Available with:

- 41" (1030 mm) blocks (shown here) and 60" (1520 mm) blocks
- Not available in PC blocks

## Planter Blocks

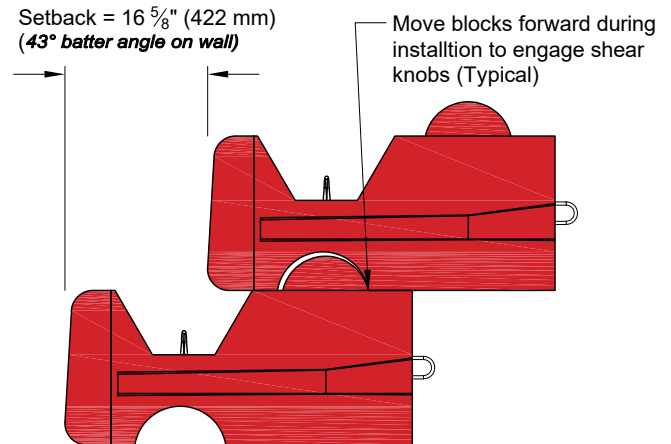
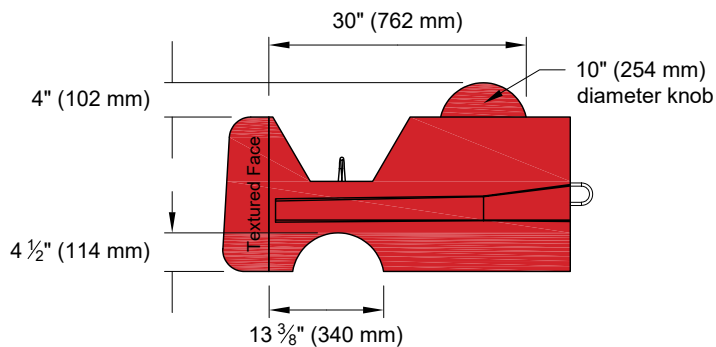

Available with:

- 41" (1030 mm) blocks (shown here) and 60" (1520 mm) blocks
- Not available in PC blocks

Redi-Rock has two options for large batter retaining walls. Both options are created by relocating the knob so that it is further back in the Redi-Rock blocks compared to our smaller batter walls (5° and less). There are two knob locations further back in the block which create the 9" (230 mm) setback block and the planter block. Blocks made with knobs in either of these locations almost exclusively use 10" (254 mm) diameter knobs.

DRAWN BY:	JRJ
UPDATED BY:	DLH
DATE:	01-03-2022
SHEET:	1 of 1

TITLE:	Block Setback Options Large Batter
FILE:	



The Redi-Rock retaining blocks are available with multiple shear knob size and location options, to permit wall batter design flexibility. This detail depicts alternating  $16\frac{5}{8}$ " (422 mm) Planter and  $1\frac{5}{8}$ " (41 mm) Standard setback blocks, however designs are possible using more than one Standard setback block between Planter blocks. The regular repetition of combinations of different setback blocks within a wall profile can have structural and aesthetic significance. Abrupt changes in wall batter that carry over multiple blocks are not recommended.

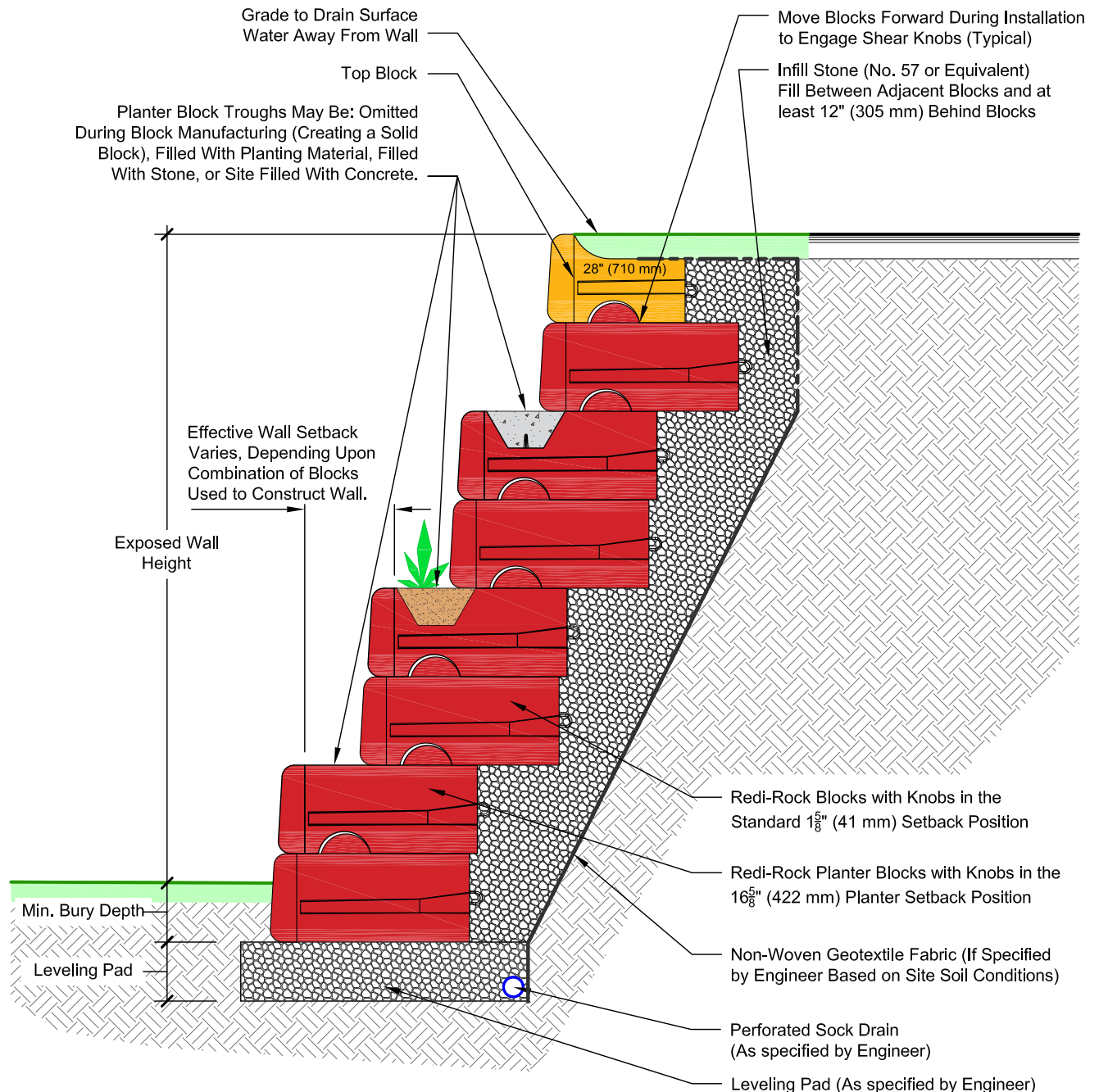

This drawing is for reference only. Determination of the suitability and/or manner of use of any details contained in this document is the sole responsibility of the design engineer of record. Final project designs, including all construction details, shall be prepared by a licensed professional engineer using the actual conditions of the proposed site. Final wall design must address both internal and external drainage and all modes of wall stability.

DRAWN BY:	B. Lindfors
APPROVED BY:	J. Johnson
DATE:	Jan 28, 2016
SHEET:	1 of 1

TITLE:	<b>Alternating Planter &amp; Standard Batter Block Wall Section</b>
FILE:	Alt Planter & Standard Batter Wall Section 012816.dwg



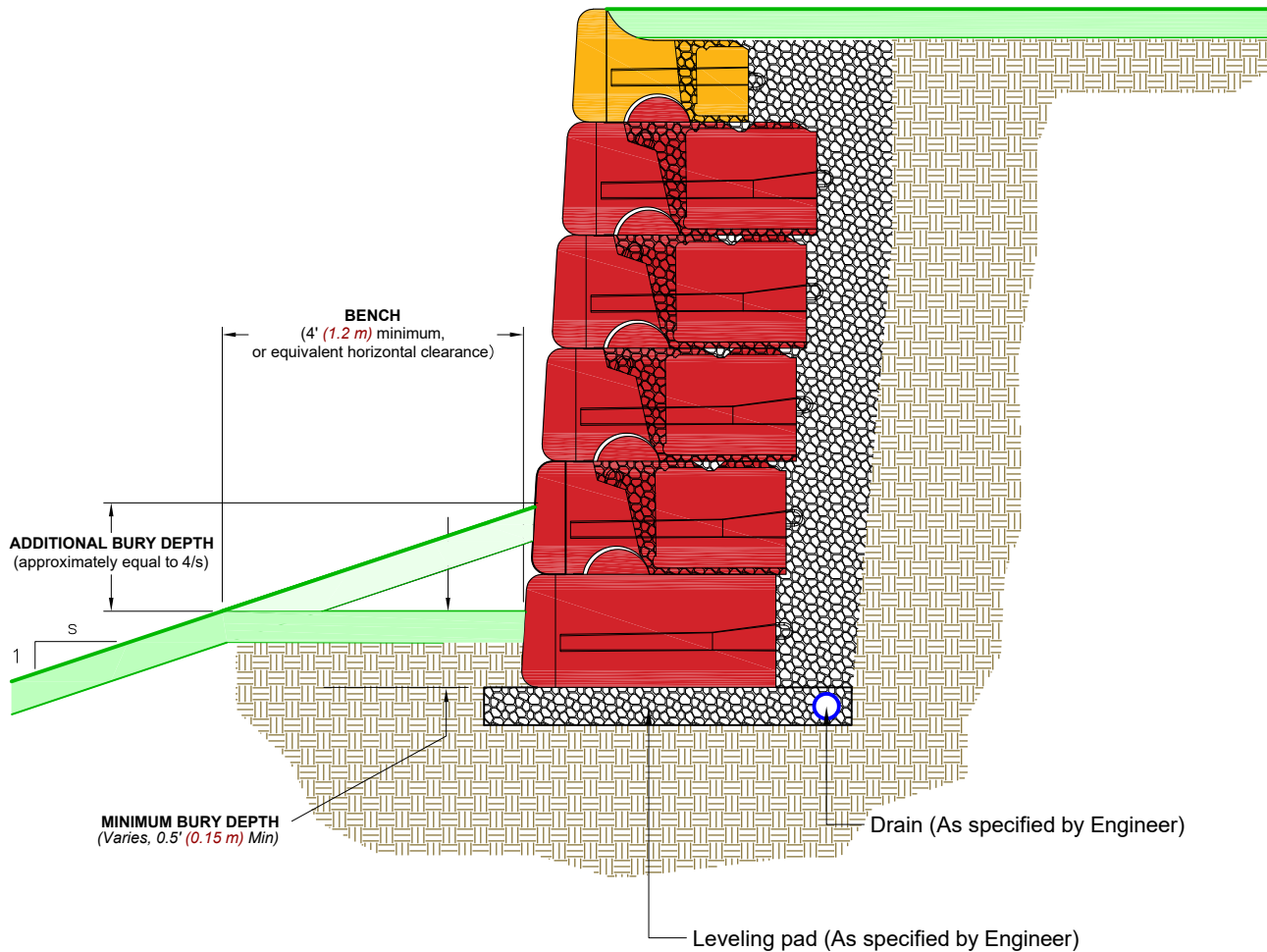

This drawing is for reference only. Determination of the suitability and/or manner of use of any details contained in this document is the sole responsibility of the design engineer of record. Final project designs, including all construction details, shall be prepared by a licensed professional engineer using the actual conditions of the proposed site.

The guidance provided is based upon generally accepted engineering principles, and should be considered a "rule of thumb." It should be noted that toe slopes generally decrease global stability and bearing capacity. These should be checked and verified by the responsible party.

DRAWN BY:	DLH
APPROVED BY:	NWL
DATE:	5/28/2021
SHEET:	1 of 1

TITLE:	Typical Toe Slope Detail
FILE:	

