

# Typical Reinforced Wall Section

**Note:**

One degree or zero degree batter angle walls are available using blocks with 7 1/2" (190 mm) or 6 3/4" (171 mm) knobs (Specialty items)

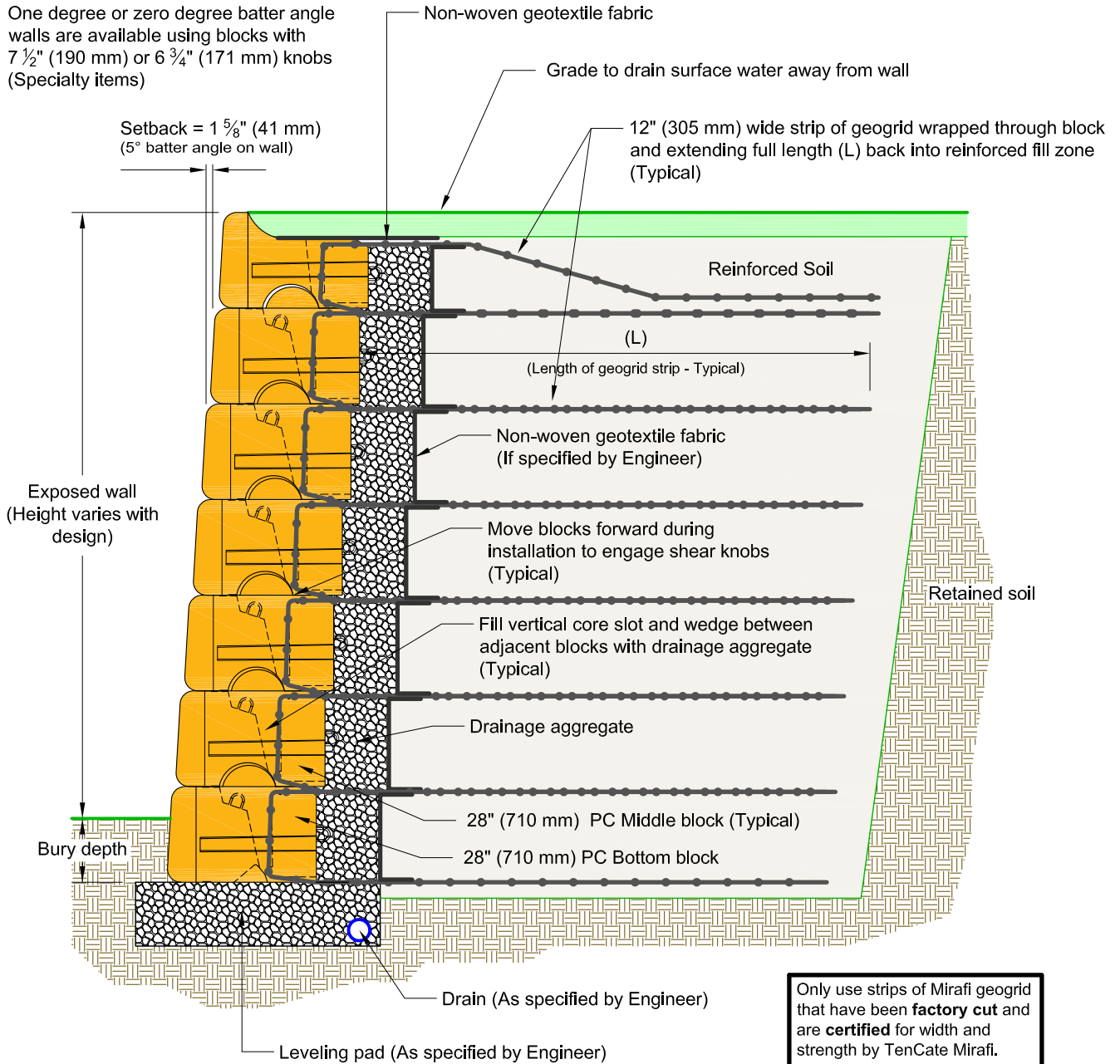

This drawing is for reference only. Determination of the suitability and/or manner of use of any details contained in this document is the sole responsibility of the design engineer of record. Final project designs, including all construction details, shall be prepared by a licensed professional engineer using the actual conditions of the proposed site.

DRAWN BY:	JRJ
APPROVED BY:	JRJ
DATE:	17MAR2016
SHEET:	1 of 1

TITLE:	Typical Reinforced Wall Section
FILE:	2 Typical Gravity Wall Section 031716.dwg



# POSITIVE CONNECTION (PC) DETAILS

NO SCALE

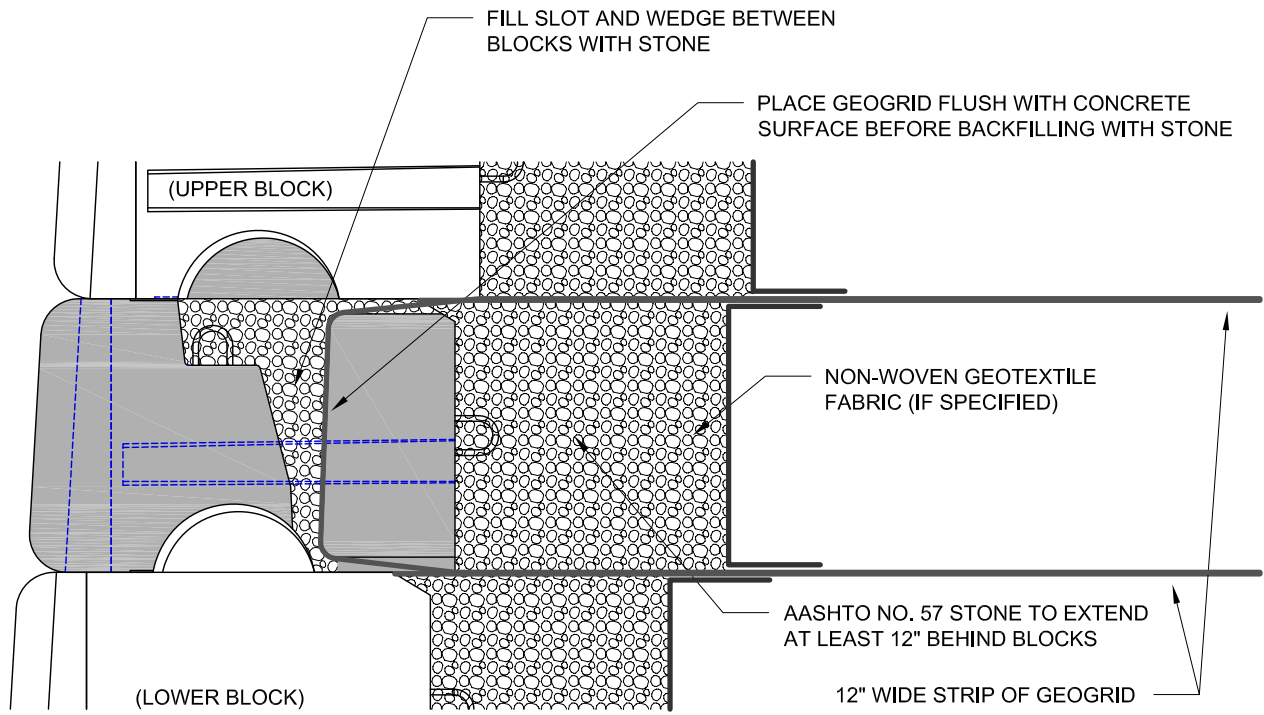

## SECTION VIEW THROUGH BLOCKS

NO SCALE

GEOGRID STRIP WRAPS THROUGH BLOCK AND EXTENDS FULL LENGTH (L) INTO REINFORCED FILL ZONE (TYPICAL)

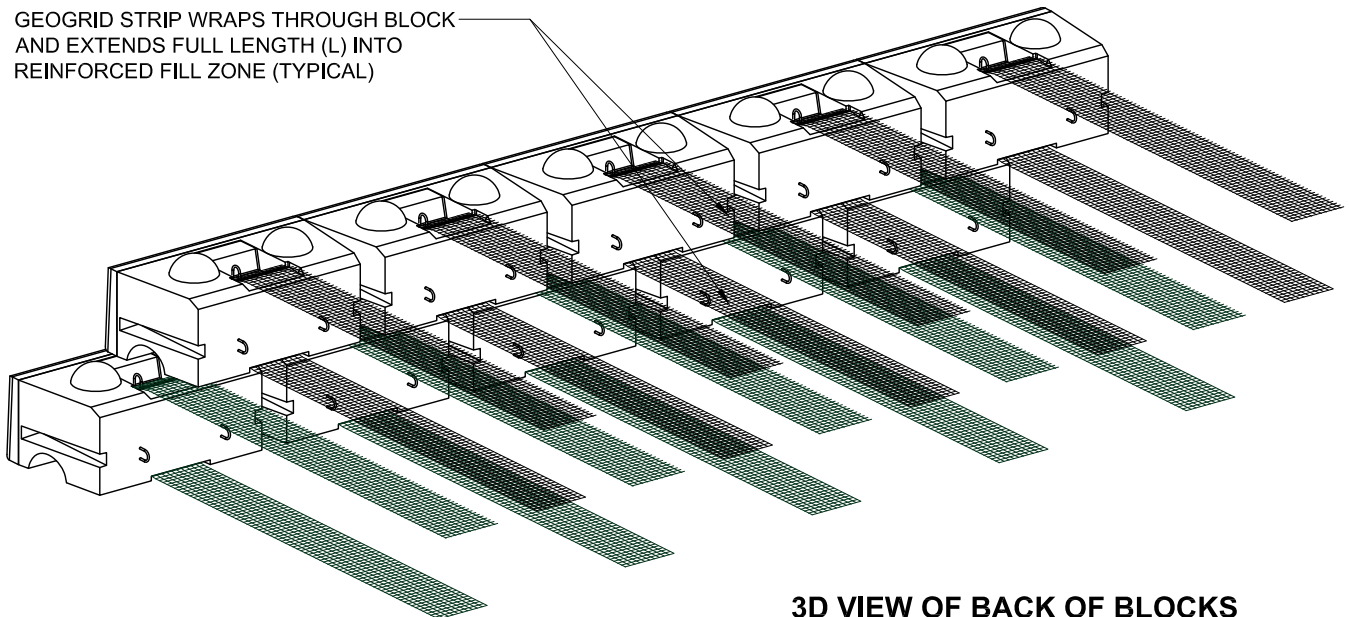

## 3D VIEW OF BACK OF BLOCKS

NO SCALE

DRAWN BY:	JRJ
APPROVED BY:	JRJ
DATE:	06-22-2015
SHEET:	1 of 1

TITLE:	<h1>Positive Connection Detail</h1>	
FILE:		1 Positive Connection Detail 062215.dwg





### Geogrid Layout for Convex Curves and Radial Corners

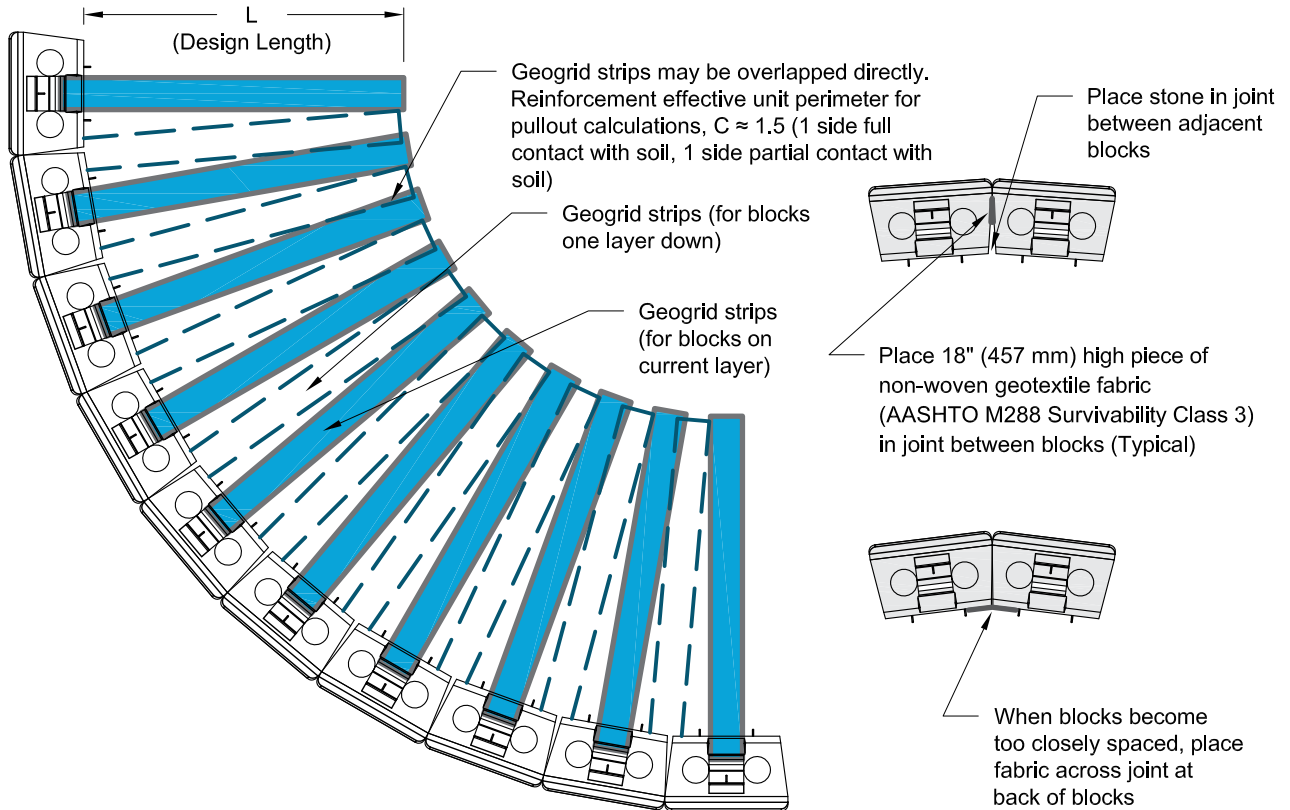

### Minimum radius for bottom row

Number of courses	Height of wall	Radius from face of block	Distance between blocks*
1	1'-6" (0.46 m)	14'-6" (4.42 m)	0.13" (3 mm)
2	3'-0" (0.91 m)	14'-8" (4.47 m)	0.21" (5 mm)
3	4'-6" (1.37 m)	14'-10" (4.52 m)	0.28" (7 mm)
4	6'-0" (1.83 m)	15'-0" (4.57 m)	0.36" (9 mm)
5	7'-6" (2.29 m)	15'-2" (4.62 m)	0.43" (11 mm)
6	9'-0" (2.74 m)	15'-4" (4.67 m)	0.50" (13 mm)
7	10'-6" (3.20 m)	15'-6" (4.72 m)	0.57" (15 mm)
8	12'-0" (3.66 m)	15'-8" (4.78 m)	0.63" (16 mm)
9	13'-6" (4.11 m)	15'-10" (4.83 m)	0.70" (18 mm)
10	15'-0" (4.57 m)	16'-0" (4.88 m)	0.76" (19 mm)
11	16'-6" (5.03 m)	16'-2" (4.93 m)	0.83" (21 mm)
12	18'-0" (5.49 m)	16'-4" (4.98 m)	0.88" (22 mm)
13	19'-6" (5.94 m)	16'-6" (5.03 m)	0.95" (24 mm)
14	21'-0" (6.40 m)	16'-8" (5.08 m)	1.01" (26 mm)

14'-6" (4.42 m) is the minimum radius for Redi-Rock blocks. It occurs when all the blocks are placed tight together. A larger radius is required on the bottom row of a Redi-Rock wall to account for the batter between courses of blocks and still provide enough space to construct the top row of blocks.

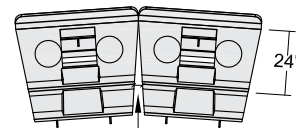

**Top View**

\* Distance between blocks

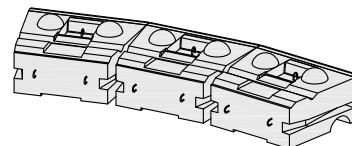

**Back View**

\* Distance between blocks is measured at the back of 28" (710 mm) blocks and 24" (610 mm) behind the form parting line (back edge of face texture) for 41" (1030 mm) blocks. This distance is intended to be a guide only. Minimum radius is controlling.

This drawing is for reference only. Determination of the suitability and/or manner of use of any details contained in this document is the sole responsibility of the design engineer of record. Final project designs, including all construction details, shall be prepared by a licensed professional engineer using the actual conditions of the proposed site.

## Geogrid Layout for Concave Curves and Radial Corners

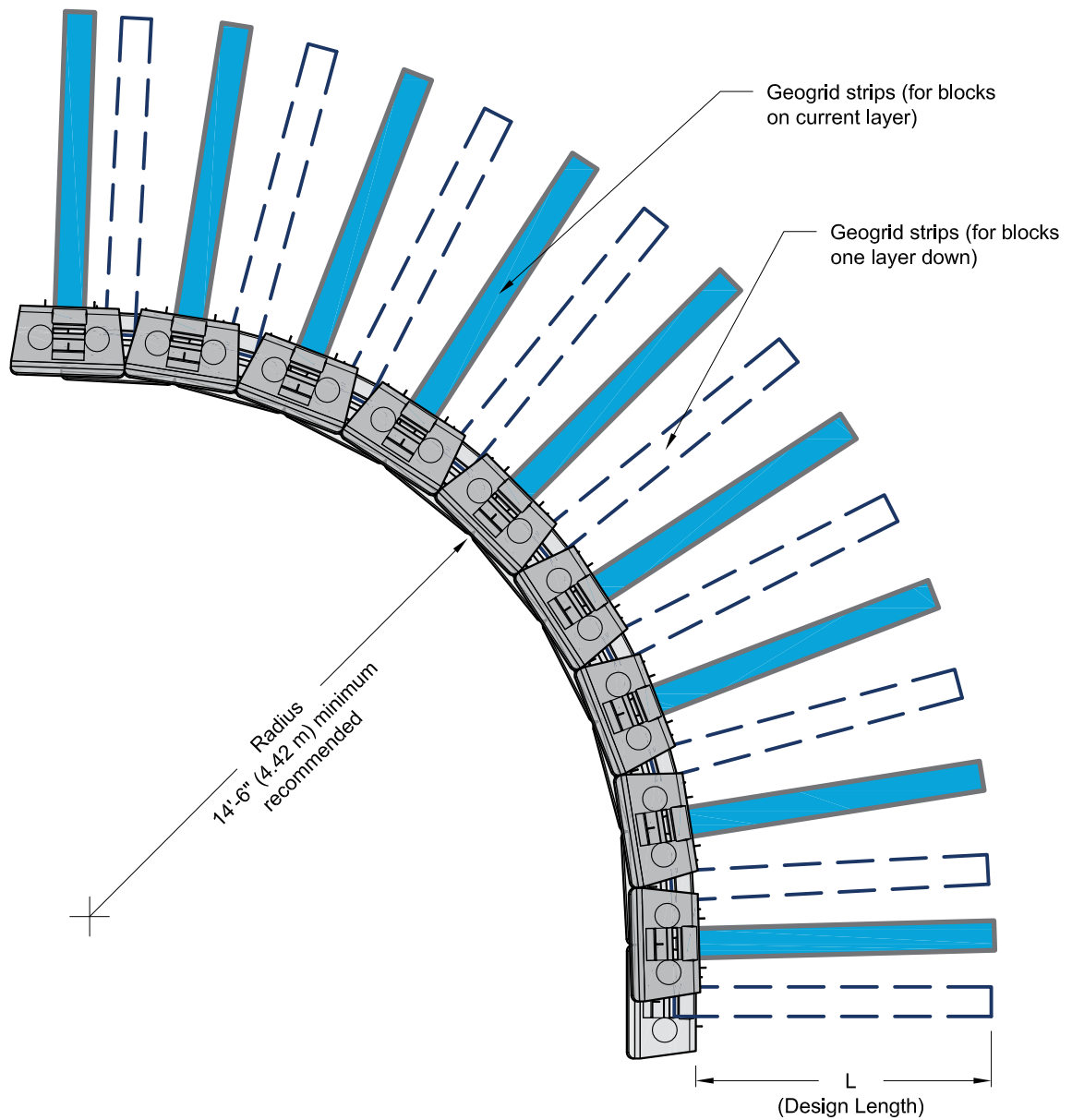

This drawing is for reference only. Determination of the suitability and/or manner of use of any details contained in this document is the sole responsibility of the design engineer of record. Final project designs, including all construction details, shall be prepared by a licensed professional engineer using the actual conditions of the proposed site.



### Geogrid Layout for 90° Inside Corner

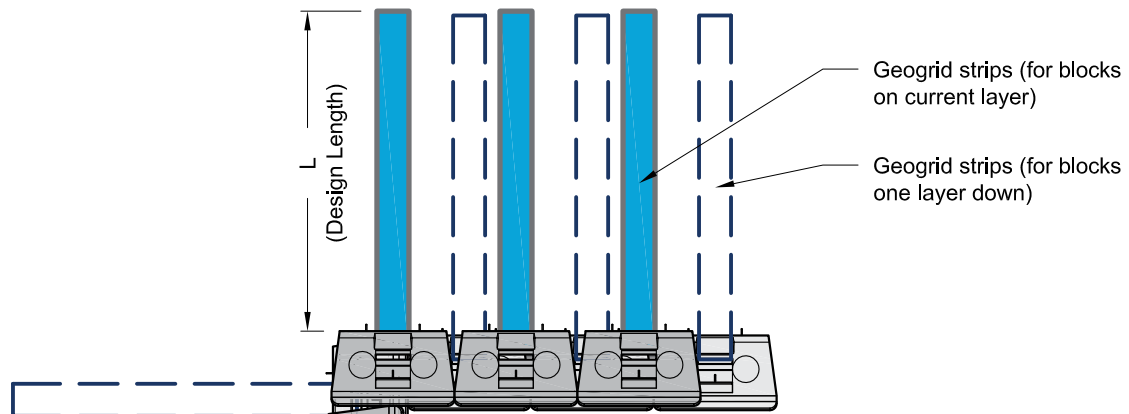

**Top View**

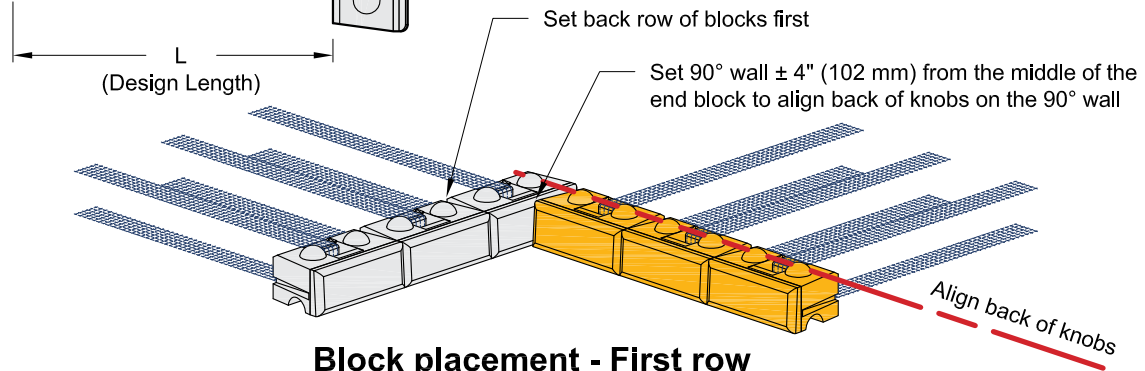

**Block placement - First row**

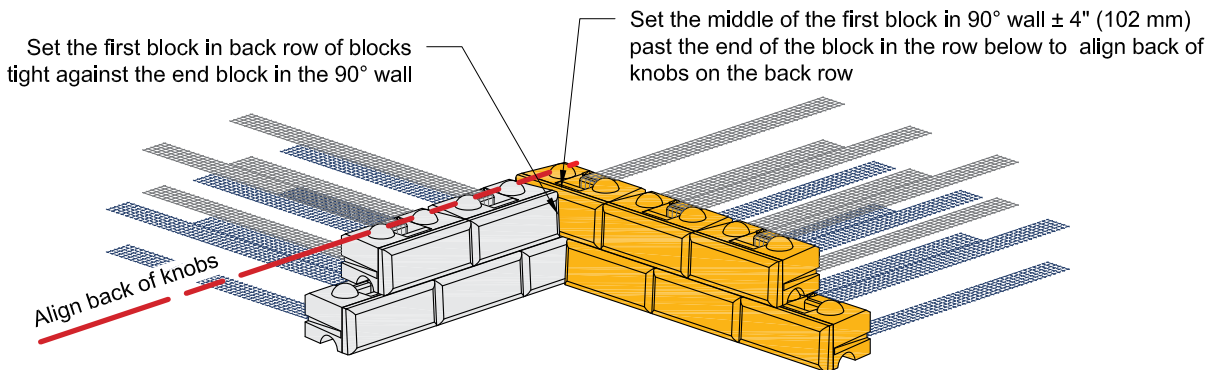

**Block placement - Second row**

This drawing is for reference only. Determination of the suitability and/or manner of use of any details contained in this document is the sole responsibility of the design engineer of record. Final project designs, including all construction details, shall be prepared by a licensed professional engineer using the actual conditions of the proposed site.

### Geogrid Layout for 90° Outside Corner

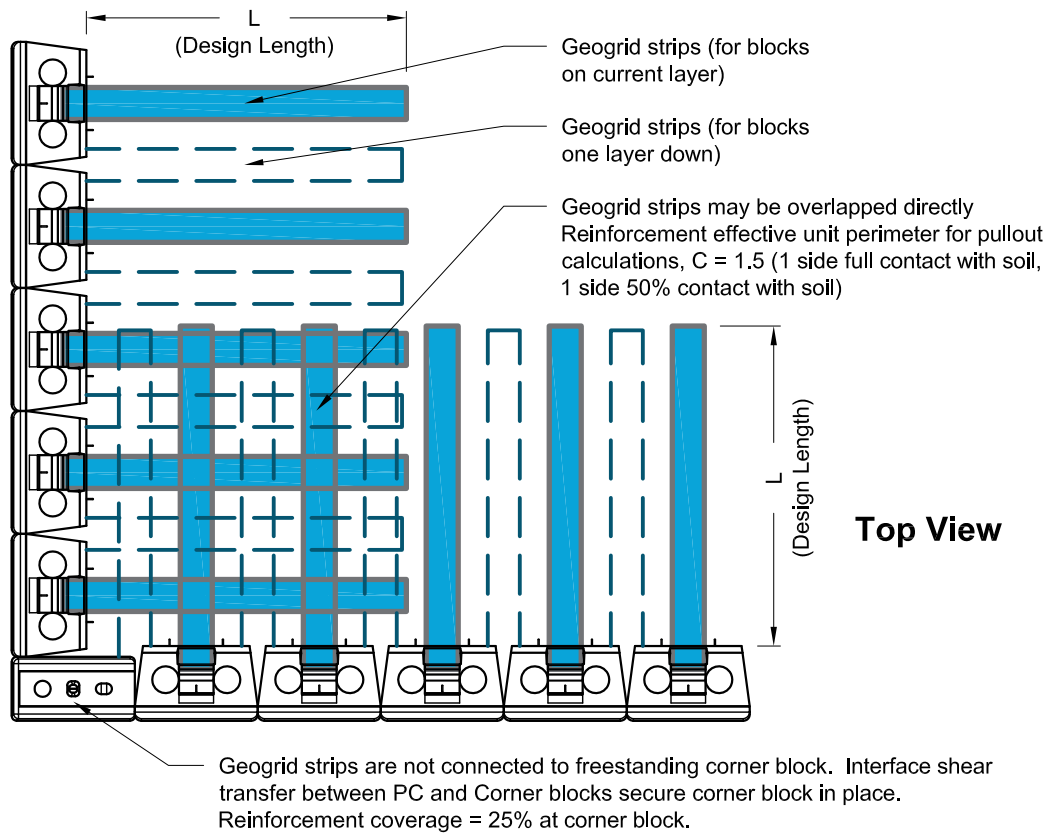

### Block Layout for 90° Outside Corner

The top row of blocks are shown in red. They have been cutout in line with their bottom grooves to show how they fit with the knobs on the bottom row of block. The geogrid strips are not shown for clarity.

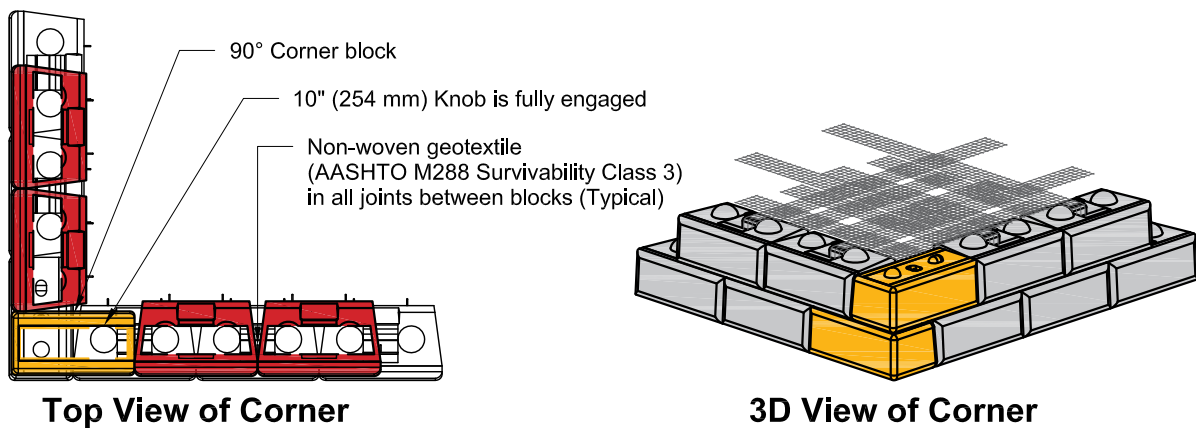

This drawing is for reference only. Determination of the suitability and/or manner of use of any details contained in this document is the sole responsibility of the design engineer of record. Final project designs, including all construction details, shall be prepared by a licensed professional engineer using the actual conditions of the proposed site.

Gravity block 28" with grid using pinch technique

(VP) = Vertical placement of geogrid layers. Measurements are from the base elevation.

(L) = Length of geogrid. Measurements are from the face of the block.

Note:  
Load Condition A Shown  
(No Backslope - No Surcharge)

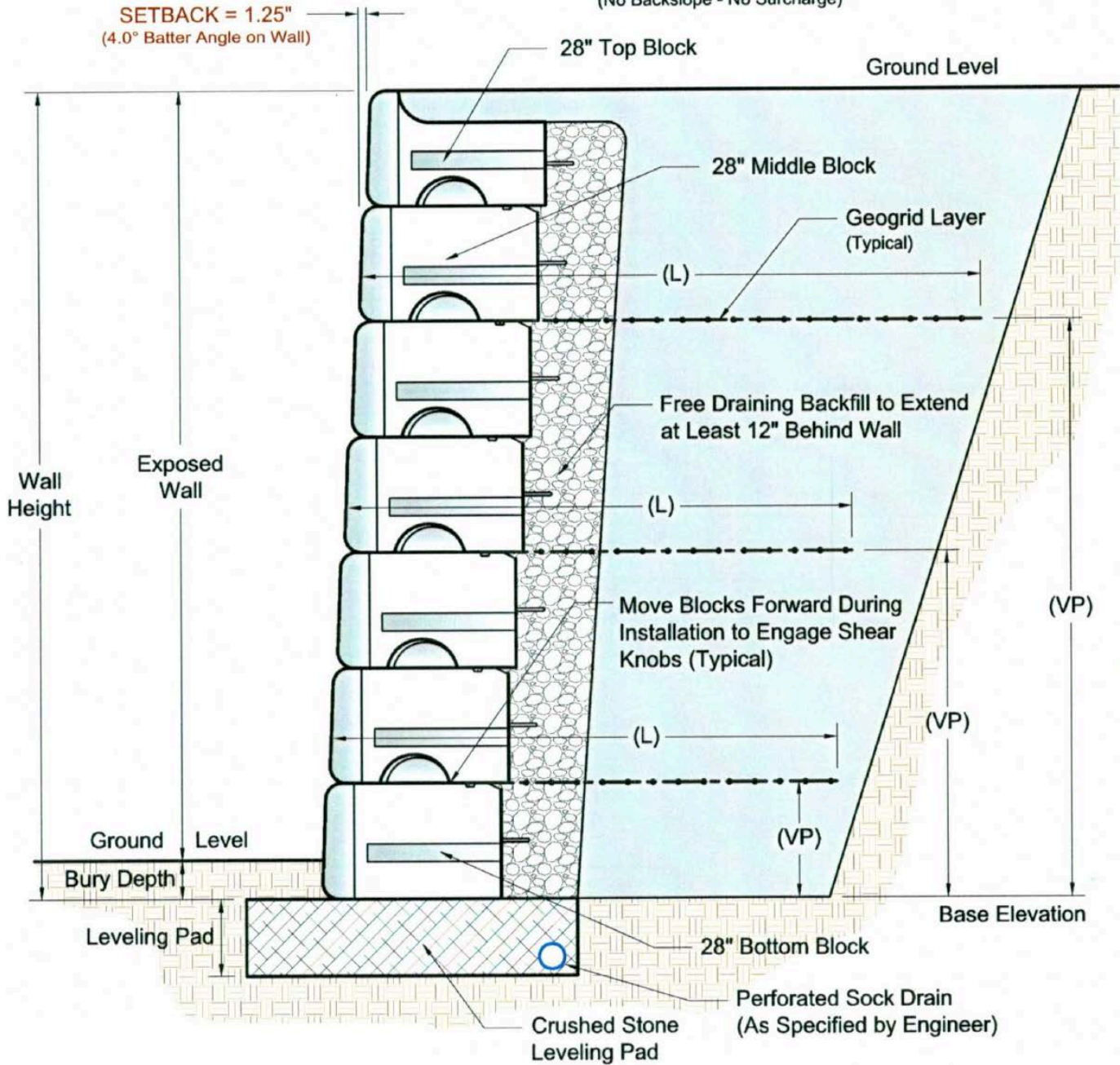

This drawing is for reference only. Determination of the suitability and/or manner of use of any details contained in this document is the sole responsibility of the design engineer of record. Final project designs, including all construction details, shall be prepared by a licensed professional engineer using the actual conditions of the proposed site.